



WELL-X-TROL®

Diaphragm Well Tanks: WX-100C-DD and WX-400C Series ASME

125 PSIG Working Pressure

Construction

Shell	ASME Approved Steel
Diaphragm	Heavy Duty Buty
Liner	Antimicrobial Polypropylene w/ Anti-Legionella Protection
System Connection	Stainless Steel (NPTM) WX-101C-DD through WX-103C-DD Malleable Iron (NPTF) WX-401C through WX-407C
Finish	Red Oxide Primer
Water Circulator	Turbulator™
Air Valve	Schrader Valve w/EPDM Seat
Factory Precharge	25 PSIG (1.7 bar)

Performance

Maximum Operating Temperature	200°F (93°C)
Maximum Working Pressure	125 PSIG (8.6 bar)
Warranty	1-Year

Application

- For use in commercial well water and booster pump systems.
- Fixed diaphragm construction.
- Designed and constructed per ASME Code Section VIII, Division 1.
- Tested to JIS Z 2801 for reduction of Legionella, Staphylococcus and E. coli.
- Follows ASHRAE 188 Anti-Legionella guidelines.
- Sight glass and seismic restraint options available.

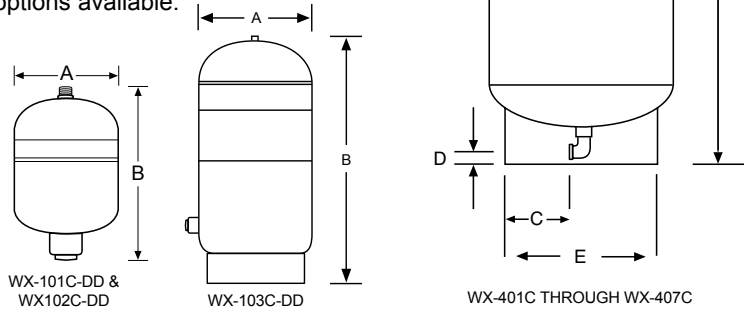

ASME Models

Model Number	Tank Volume		Max. Accept. Volume		A Tank Height		B Tank Diameter		C Sys. Conn. Inset		D Sys. Conn. Centerline		E Stand Diameter		System Conn.	Shipping Weight	
	Gal	Lit	Gal	Lit	In	mm	In	mm	In	mm	In	mm	In	mm		In	Lbs
WX-101C-DD	2.0	8	.9	3.5	14	356	8	203	-	-	-	-	-	-	¾ NPTM	10	5
WX-102C-DD	6.4	24	3.2	12	18	457	12	305	-	-	-	-	-	-	¾ NPTM	26	12
WX-103C-DD	8.6	33	3.2	12	22	559	12	305	-	-	-	-	10¾	273	¾ NPTM	36	16
WX-401C	18	68	11	42	31	787	16	406	5	124	1½	38	12¾	324	1 NPTF	77	35
WX-402C	25	95	11	42	40	1016	16	406	5	124	1½	38	12¾	324	1 NPTF	93	42
WX-403C	34	129	11	42	49	1245	16	406	5	124	1½	38	12¾	324	1 NPTF	115	52
WX-404C	68	258	34	129	48	1219	24	610	6	159	1⅝	41	16	406	1¼ NPTF	227	103
WX-405C	90	341	34	129	59	1499	24	610	6	159	1⅝	41	16	406	1¼ NPTF	252	114
WX-406C	110	417	34	129	70	1778	24	610	6	159	1⅝	41	16	406	1¼ NPTF	286	130
WX-407C	132	500	46	175	57	1448	30	762	10	254	1¾	44	24	610	1¼ NPTF	436	198

All dimensions and weights are approximate.

Job Name _____	Notes _____
Engineer _____	_____
Contractor _____	_____
P.O. No. _____	_____
Sales Rep. _____	_____
Model No. _____	_____





WELL-X-TROL®

Diaphragm Well Tanks: WX-100C-DD and WX-400C Series ASME

150 PSIG Working Pressure

Construction

Shell	ASME Approved Steel
Diaphragm	Heavy Duty Buty
Liner	Antimicrobial Polypropylene w/ Anti-Legionella Protection
System Connection	Stainless Steel (NPTM) WX-101C-DD through WX-103C-DD Malleable Iron (NPTF) WX-401C through WX-407C
Finish	Red Oxide Primer
Water Circulator	Turbulator™
Air Valve	Schrader Valve w/EPDM Seat
Factory Precharge	25 PSIG (1.7 bar)

Performance

Maximum Operating Temperature	200°F (93°C)
Maximum Working Pressure	150 PSIG (10.3 bar)
Warranty	1-Year

Application

- For use in commercial well water and booster pump systems.
- Fixed diaphragm construction.
- Designed and constructed per ASME Code Section VIII, Division 1.
- Tested to JIS Z 2801 for reduction of Legionella, Staphylococcus and E. coli.
- Follows ASHRAE 188 Anti-Legionella guidelines.
- Sight glass and seismic restraint options available.

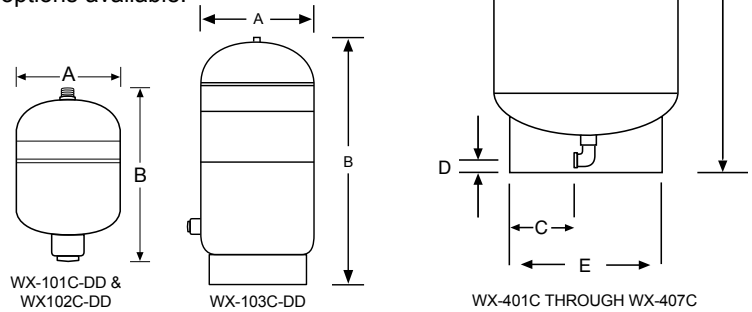

ASME Models

Model Number	Tank Volume		Max. Accept. Volume		A Tank Height		B Tank Diameter		C Sys. Conn. Inset		D Sys. Conn. Centerline		E Stand Diameter		System Conn.	Shipping Weight	
	Gal.	Lit.	Gal.	Lit.	In	mm	In	mm	In	mm	In	mm	In	mm	In	Lbs	Kg
WX-101C-DD	2.0	8	.9	3.5	14	356	8	203	-	-	-	-	-	-	¾ NPTM	10	5
WX-102C-DD	6.4	24	3.2	12	18	457	12	305	-	-	-	-	-	-	¾ NPTM	26	12
WX-103C-DD	8.6	33	3.2	12	22	559	12	305	-	-	-	-	10¾	273	¾ NPTM	36	16
WX-401C	18	68	11	42	31	787	16	406	5	124	1½	38	12¾	324	1 NPTF	96	44
WX-402C	25	95	11	42	40	1016	16	406	5	124	1½	38	12¾	324	1 NPTF	113	51
WX-403C	34	129	11	42	49	1245	16	406	5	124	1½	38	12¾	324	1 NPTF	120	54
WX-404C	68	258	34	129	48	1219	24	610	6	159	1⅝	41	16	406	1¼ NPTF	232	105
WX-405C	90	341	34	129	59	1499	24	610	6	159	1⅝	41	16	406	1¼ NPTF	255	116
WX-406C	110	417	34	129	70	1778	24	610	6	159	1⅝	41	16	406	1¼ NPTF	335	152
WX-407C	132	500	46	175	57	1448	30	762	10	254	1¾	44	24	610	1¼ NPTF	450	204

All dimensions and weights are approximate.

Job Name _____	Notes _____
Engineer _____	_____
Contractor _____	_____
P.O. No. _____	_____
Sales Rep. _____	_____
Model No. _____	_____





WELL-X-TROL®

Diaphragm Well Tanks: WX-100C-DD and WX-400C Series ASME

175 PSIG Working Pressure

Construction

Shell	ASME Approved Steel
Diaphragm	Heavy Duty Buty
Liner	Antimicrobial Polypropylene w/ Anti-Legionella Protection
System Connection	Stainless Steel (NPTM) WX-101C-DD through WX-103C-DD Malleable Iron (NPTF) WX-401C through WX-407C
Finish	Red Oxide Primer
Water Circulator	Turbulator™
Air Valve	Schrader Valve w/EPDM Seat
Factory Precharge	25 PSIG (1.7 bar)

Performance

Maximum Operating Temperature	200°F (93°C)
Maximum Working Pressure	175 PSIG (12.0 bar)
Warranty	1-Year

Application

- For use in commercial well water and booster pump systems.
- Fixed diaphragm construction.
- Designed and constructed per ASME Code Section VIII, Division 1.
- Tested to JIS Z 2801 for reduction of Legionella, Staphylococcus and E. coli.
- Follows ASHRAE 188 Anti-Legionella guidelines.
- Sight glass and seismic restraint options available.

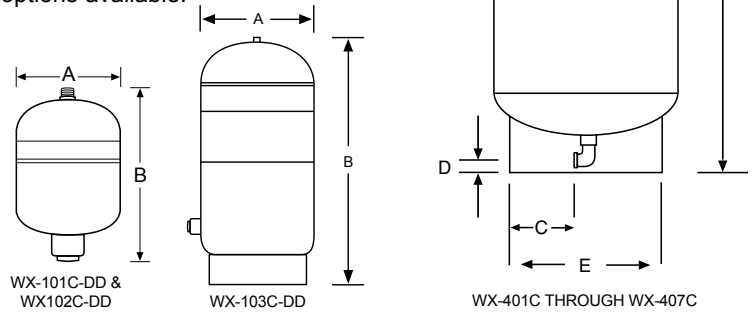

ASME Models

Model Number	Tank Volume		Max. Accept. Volume		A Tank Height		B Tank Diameter		C Sys. Conn. Inset		D Sys. Conn. Centerline		E Stand Diameter		System Conn.	Shipping Weight	
	Gal.	Lit.	Gal.	Lit.	In	mm	In	mm	In	mm	In	mm	In	mm	In	Lbs	Kg
WX-101C-DD	2.0	8	.9	3.5	14	356	8	203	-	-	-	-	-	-	¾ NPTM	10	5
WX-102C-DD	6.4	24	3.2	12	18	457	12	305	-	-	-	-	-	-	¾ NPTM	26	12
WX-103C-DD	8.6	33	3.2	12	22	559	12	305	-	-	-	-	10¾	273	¾ NPTM	36	16
WX-401C	18	68	11	42	31	787	16	406	5	124	1½	38	12¾	324	1 NPTF	110	50
WX-402C	25	95	11	42	40	1016	16	406	5	124	1½	38	12¾	324	1 NPTF	125	57
WX-403C	34	129	11	42	49	1245	16	406	5	124	1½	38	12¾	324	1 NPTF	145	66
WX-404C	68	258	34	129	48	1219	24	610	6	159	1¾	41	16	406	1¼ NPTF	313	142
WX-405C	90	341	34	129	59	1499	24	610	6	159	1¾	41	16	406	1¼ NPTF	384	174
WX-406C	110	417	34	129	70	1778	24	610	6	159	1¾	41	16	406	1¼ NPTF	402	182
WX-407C	132	500	46	175	57	1448	30	762	10	254	1¾	44	24	610	1¼ NPTF	510	231

Job Name _____	Notes _____
Engineer _____	_____
Contractor _____	_____
P.O. No. _____	_____
Sales Rep. _____	_____
Model No. _____	_____





WELL-X-TROL®

Diaphragm Well Tanks: WX-400C Series ASME

250 PSIG Working Pressure

Construction

Shell	ASME Approved Steel
Diaphragm	Heavy Duty Butyl
Liner	Antimicrobial Polypropylene w/ Anti-Legionella Protection
System Connection	Malleable Iron (NPTF)
Finish	Red Oxide Primer
Water Circulator	Turbulator™
Air Valve	Schrader Valve w/EPDM Seat
Factory Precharge	25 PSIG (1.7 bar)

Performance

Maximum Operating Temperature	200°F (93°C)
Maximum Working Pressure	250 PSIG (17.2 bar)
Warranty	1-Year

Application

- For use in commercial well water and booster pump systems.
- Fixed diaphragm construction.
- Designed and constructed per ASME Code Section VIII, Division 1.
- Tested to JIS Z 2801 for reduction of Legionella, Staphylococcus and E. coli.
- Follows ASHRAE 188 Anti-Legionella guidelines.
- Sight glass and seismic restraint options available.

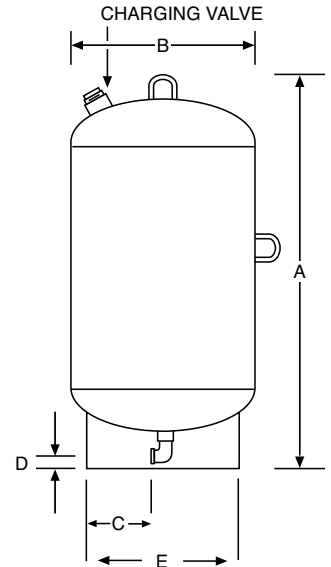

WX-401C THROUGH WX-407C

ASME Models

Model Number	Tank Volume		Max. Accept. Volume		A Tank Height		B Tank Diameter		C Sys. Conn. Inset		D Sys. Conn. Centerline		E Stand Diameter		System Conn. (NPTF)	Shipping Weight	
	Gal.	Lit.	Gal.	Lit.	In.	mm	In.	mm	In.	mm	In.	mm	In.	mm		Lbs	Kg
WX-401C	18	68	11	42	31	787	16	406	5	124	1½	38	12¾	324	1	126	57
WX-402C	25	95	11	42	40	1016	16	406	5	124	1½	38	12¾	324	1	145	65
WX-403C	34	129	11	42	49	1245	16	406	5	124	1½	38	12¾	324	1	183	83
WX-404C	68	258	34	129	48	1219	24	610	6	159	1⅝	41	16	406	1¼	411	186
WX-405C	90	341	34	129	59	1499	24	610	6	159	1⅝	41	16	406	1¼	433	196
WX-406C	110	417	34	129	70	1778	24	610	6	159	1⅝	41	16	406	1¼	475	215
WX-407C	132	500	46	175	57	1448	30	762	10	254	1¾	44	24	610	1¼	570	259

All dimensions and weights are approximate.

Job Name _____	Notes _____
Engineer _____	_____
Contractor _____	_____
P.O. No. _____	_____
Sales Rep. _____	_____
Model No. _____	_____



Certified to NSF/ANSI CAN 61





WELL-X-TROL®

Diaphragm Well Tanks: WX-400C Series ASME

300 PSIG Working Pressure

Construction

Shell	ASME Approved Steel
Diaphragm	Heavy Duty Butyl
Liner	Antimicrobial Polypropylene w/ Anti-Legionella Protection
System Connection	Malleable Iron (NPTF)
Finish	Red Oxide Primer
Water Circulator	Turbulator™
Air Valve	Schrader Valve w/EPDM Seat
Factory Precharge	25 PSIG (1.7 bar)

Performance

Maximum Operating Temperature	200°F (93°C)
Maximum Working Pressure	300 PSIG (20.7 bar)
Warranty	1-Year

Application

- For use in commercial well water and booster pump systems.
- Fixed diaphragm construction.
- Designed and constructed per ASME Code Section VIII, Division 1.
- Tested to JIS Z 2801 for reduction of Legionella, Staphylococcus and E. coli.
- Follows ASHRAE 188 Anti-Legionella guidelines.
- Sight glass and seismic restraint options available.

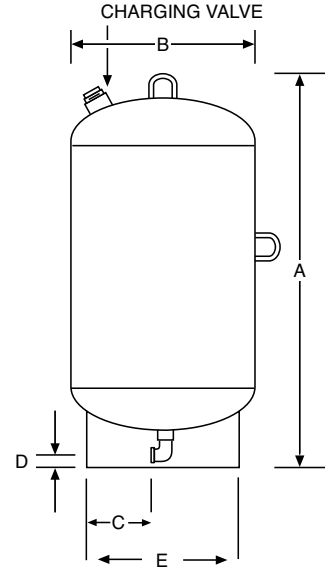

ASME Models

Model Number	Tank Volume		Max. Accept. Volume		A Tank Height		B Tank Diameter		C Sys. Conn. Inset		D Sys. Conn. Centerline		E Stand Diameter		System Conn. (NPTF)	Shipping Weight	
	Gal	Lit	Gal	Lit	In	mm	In	mm	In	mm	In	mm	In	mm		Lbs	Kg
WX-401C	18	68	11	42	31	787	16	406	5	124	1½	38	12¾	324	1	133	60
WX-402C	25	95	11	42	40	1016	16	406	5	124	1½	38	12¾	324	1	160	73
WX-403C	34	129	11	42	49	1245	16	406	5	124	1½	38	12¾	324	1	200	91
WX-404C	68	258	34	129	48	1219	24	610	6	159	1⅝	41	16	406	1¼	432	196
WX-405C	90	341	34	129	59	1499	24	610	6	159	1⅝	41	16	406	1¼	460	209
WX-406C	110	417	34	129	70	1778	24	610	6	159	1⅝	41	16	406	1¼	500	227
WX-407C	132	500	46	175	57	1448	30	762	10	254	1¾	44	24	610	1¼	625	284

All dimensions and weights are approximate.

Job Name _____	Notes _____
Engineer _____	_____
Contractor _____	_____
P.O. No. _____	_____
Sales Rep. _____	_____
Model No. _____	_____



Certified to NSF/ANSI CAN 61





WELL-X-TROL®

Full Acceptance Bladder Well Tanks: WX-440C – WX-460C Series ASME

125 PSIG Working Pressure

Construction

Shell	ASME Approved Steel
Full Acceptance Bladder	Heavy Duty Butyl
Bladder Thickness	.100 In. Minimum
System Connection	Malleable Iron (NPTF)
Finish	Red Oxide Primer
Air Valve	Schrader Valve w/EPDM Seats
Factory Precharge	25 PSIG (1.7 bar)

Performance

Maximum Operating Temperature	240°F (115°C)
Maximum Working Pressure	125 PSIG (8.6 bar)
Warranty	1-Year

Application

- For use in commercial well water and booster pump systems.
- Replaceable bladder design.
- Designed and constructed per ASME Code Section VIII, Division 1.
- Sight glass and seismic restraint options available.
- Available with S/S system connection.

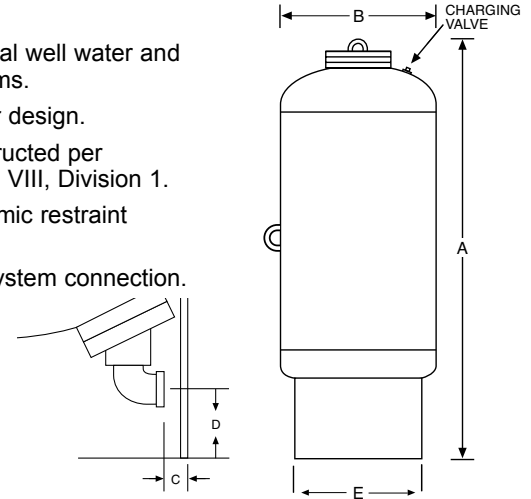

ASME Models

Model Number	Tank Volume		Max. Accept. Volume		A Tank Height		B Tank Diameter		C Sys. Conn. Inset		D Sys. Conn. Centerline		E Stand Diameter		System Conn. (NPTF)	Shipping Weight	
	Gal	Lit	Gal	Lit	In	mm	In	mm	In	mm	In	mm	In	mm		Lbs	Kg
WX-447C	53	200	53	200	45	1143	24	610	2	51	3¾	95	19	483	2	263	119
WX-448C	80	300	80	300	59	1498	24	610	2	51	3¾	95	19	483	2	315	143
WX-449C	106	400	106	400	73	1854	24	610	2	51	3¾	95	19	483	2	319	145
WX-450C	132	500	132	500	87	2210	24	610	2	51	3¾	95	19	483	2	351	159
WX-451C	158	600	158	600	73	1854	30	762	3½	89	5½	140	24	610	2	493	224
WX-452C	211	800	211	800	91	2311	30	762	3½	89	5½	140	24	610	2	602	273
WX-453C	264	1000	264	1000	86	2184	36	914	3⅝	98	6¾	171	30	762	3	676	307
WX-454C	317	1200	317	1200	98	2489	36	914	3⅝	98	6¾	171	30	762	3	762	346
WX-455C	370	1400	370	1400	110	2794	36	914	3⅝	98	6¾	171	30	762	3	843	382
WX-456C	422	1600	422	1600	82	2083	48	1219	7½	191	7⅞	181	42	1067	3	1154	523
WX-457C	528	2000	528	2000	97	2464	48	1219	7½	191	7⅞	181	42	1067	3	1331	604
WX-458C	660	2500	660	2500	84	2134	60	1524	7⅞	194	7⅞	181	54	1372	4	1450	658
WX-459C	792	3000	792	3000	99	2515	60	1524	7⅞	194	7⅞	181	54	1372	4	2169	984
WX-460C	925	3500	925	3500	107	2718	60	1524	7⅞	194	7⅞	181	54	1372	4	2300	1043
WX-461C	1056	4000	1056	4000	121	3073	60	1524	7⅞	194	7⅞	181	54	1372	4	2638	1197
WX-462C	1320	5000	1320	5000	104	2642	72	1829	8⅝	213	4¾	121	60	1524	4	3500	1588
WX-463C	1980	7500	1980	7500	140	3556	72	1829	8	203	6	152	60	1524	4	4100	1860

All dimensions and weights are approximate.

Job Name _____	Notes _____
Engineer _____	_____
Contractor _____	_____
P.O. No. _____	_____
Sales Rep. _____	_____
Model No. _____	_____





WELL-X-TROL®

Full Acceptance Bladder Well Tanks: WX-440C – WX-460C Series ASME

150 PSIG Working Pressure

Construction

Shell	ASME Approved Steel
Full Acceptance Bladder	Heavy Duty Butyl
Bladder Thickness	.100 In. Minimum
System Connection	Malleable Iron (NPTF)
Finish	Red Oxide Primer
Air Valve	Schrader Valve w/EPDM Seats
Factory Precharge	25 PSIG (1.7 bar)

Performance

Maximum Operating Temperature	240°F (115°C)
Maximum Working Pressure	150 PSIG (10.3 bar)
Warranty	1-Year

Application

- For use in commercial well water and booster pump systems.
- Replaceable bladder design.
- Designed and constructed per ASME Code Section VIII, Division 1.
- Sight glass and seismic restraint options available.
- Available with S/S system connection.

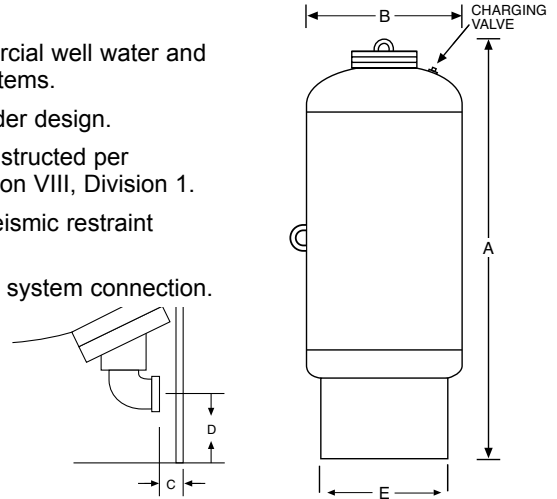

ASME Models

Model Number	Tank Volume		Max. Accept. Volume		A Tank Height		B Tank Diameter		C Sys. Conn. Inset		D Sys. Conn. Centerline		E Stand Diameter		System Conn. (NPTF)	Shipping Weight	
	Gal	Lit	Gal	Lit	In	mm	In	mm	In	mm	In	mm	In	mm		In	Lbs
WX-447C	53	200	53	200	45	1143	24	610	2	51	3¾	95	19	483	2	289	131
WX-448C	80	300	80	300	59	1498	24	610	2	51	3¾	95	19	483	2	338	153
WX-449C	106	400	106	400	73	1854	24	610	2	51	3¾	95	19	483	2	350	159
WX-450C	132	500	132	500	87	2210	24	610	2	51	3¾	95	19	483	2	392	178
WX-451C	158	600	158	600	73	1854	30	762	3½	89	5½	140	24	610	2	587	266
WX-452C	211	800	211	800	91	2311	30	762	3½	89	5½	140	24	610	2	627	284
WX-453C	264	1000	264	1000	86	2184	36	914	3⅞	98	6¾	171	30	762	3	752	341
WX-454C	317	1200	317	1200	98	2489	36	914	3⅞	98	6¾	171	30	762	3	840	381
WX-455C	370	1400	370	1400	110	2794	36	914	3⅞	98	6¾	171	30	762	3	930	422
WX-456C	422	1600	422	1600	82	2083	48	1219	7½	191	7½	181	42	1067	3	1418	643
WX-457C	528	2000	528	2000	97	2464	48	1219	7½	191	7½	181	42	1067	3	1500	680
WX-458C	660	2500	660	2500	84	2134	60	1524	7⅝	194	7⅝	181	54	1372	4	1740	789
WX-459C	792	3000	792	3000	99	2515	60	1524	7⅝	194	7⅝	181	54	1372	4	2385	1082
WX-460C	925	3500	925	3500	107	2718	60	1524	7⅝	194	7⅝	181	54	1372	4	2530	1148
WX-461C	1056	4000	1056	4000	121	3073	60	1524	7⅝	194	7⅝	181	54	1372	4	2900	1315
WX-462C	1320	5000	1320	5000	104	2642	72	1829	8⅝	213	4¾	121	60	1372	4	3850	1746
WX-463C	1980	7500	1980	7500	140	3556	72	1829	8	203	6	152	60	1372	4	4510	2046

All dimensions and weights are approximate.

Job Name _____	Notes _____
Engineer _____	_____
Contractor _____	_____
P.O. No. _____	_____
Sales Rep. _____	_____
Model No. _____	_____





WELL-X-TROL®

Full Acceptance Bladder Well Tanks: WX-440C — WX-460C Series ASME

175 PSIG Working Pressure

Construction

Shell	ASME Approved Steel
Full Acceptance Bladder	Heavy Duty Butyl
Bladder Thickness	.100 In. Minimum
System Connection	Malleable Iron (NPTF)
Finish	Red Oxide Primer
Air Valve	Schrader Valve w/EPDM Seats
Factory Precharge	25 PSIG (1.7 bar)

Performance

Maximum Operating Temperature	240°F (115°C)
Maximum Working Pressure	175 PSIG (12 bar)
Warranty	1-Year

Application

- For use in commercial well water and booster pump systems.
- Replaceable bladder design.
- Designed and constructed per ASME Code Section VIII, Division 1.
- Sight glass and seismic restraint options available.
- Available with S/S system connection.

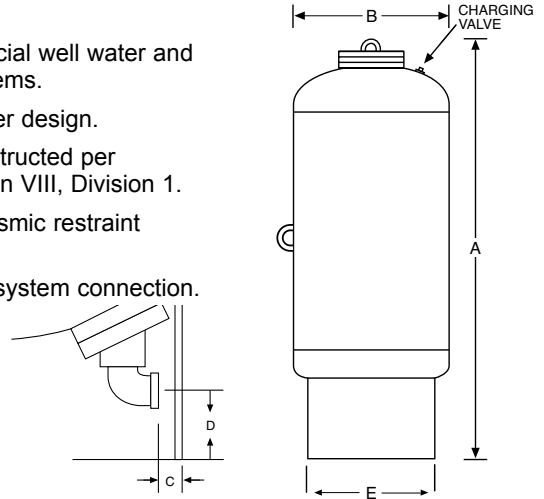

ASME Models

Model Number	Tank Volume		Max. Accept. Volume		A Tank Height		B Tank Diameter		C Sys. Conn. Inset		D Sys. Conn. Centerline		E Stand Diameter		System Conn. (NPTF)	Shipping Weight	
	Gal	Lit	Gal	Lit	In	mm	In	mm	In	mm	In	mm	In	mm		Lbs	Kg
WX-447C	53	200	53	200	45	1143	24	610	2	51	3¼	95	19	483	2	368	167
WX-448C	80	300	80	300	59	1498	24	610	2	51	3¼	95	19	483	2	430	195
WX-449C	106	400	106	400	73	1854	24	610	2	51	3¼	95	19	483	2	440	200
WX-450C	132	500	132	500	87	2210	24	610	2	51	3¼	95	19	483	2	454	206
WX-451C	158	600	158	600	73	1854	30	762	3½	89	5½	140	24	610	2	680	308
WX-452C	211	800	211	800	91	2311	30	762	3½	89	5½	140	24	610	2	694	315
WX-453C	264	1000	264	1000	86	2184	36	914	3⅝	98	6¾	171	30	762	3	846	384
WX-454C	317	1200	317	1200	98	2489	36	914	3⅝	98	6¾	171	30	762	3	959	435
WX-455C	370	1400	370	1400	110	2794	36	914	3⅝	98	6¾	171	30	762	3	1060	481
WX-456C	422	1600	422	1600	82	2083	48	1219	7½	191	7⅝	181	42	1067	3	1655	751
WX-457C	528	2000	528	2000	97	2464	48	1219	7½	191	7⅝	181	42	1067	3	1870	848
WX-458C	660	2500	660	2500	84	2134	60	1524	7⅞	194	7⅝	181	54	1372	4	2030	921
WX-459C	792	3000	792	3000	99	2515	60	1524	7⅞	194	7⅝	181	54	1372	4	3036	1377
WX-460C	925	3500	925	3500	107	2718	60	1524	7⅞	194	7⅝	181	54	1372	4	3220	1461
WX-461C	1056	4000	1056	4000	121	3073	60	1524	7⅞	194	7⅝	181	54	1372	4	3695	1676
WX-462C	1320	5000	1320	5000	104	2642	72	1829	8⅞	213	4¾	121	60	1372	4	4900	2223
WX-463C	1980	7500	1980	7500	140	3556	72	1829	8	203	6	152	60	1372	4	5740	2604

All dimensions and weights are approximate.

Job Name _____	Notes _____
Engineer _____	_____
Contractor _____	_____
P.O. No. _____	_____
Sales Rep. _____	_____
Model No. _____	_____





WELL-X-TROL®

Full Acceptance Bladder Well Tanks: WX-440C – WX-460C Series ASME

250 PSIG Working Pressure

Construction

Shell	ASME Approved Steel
Full Acceptance Bladder	Heavy Duty Butyl
Bladder Thickness	.100 In. Minimum
Finish	Red Oxide Primer
Air Valve	Schrader Valve w/EPDM Seats
Factory Precharge	25 PSIG (1.7 bar)

Performance

Maximum Operating Temperature	240°F (115°C)
Maximum Working Pressure	250 PSIG (17.2 bar)
Warranty	1-Year

Application

- For use in commercial well water and booster pump systems.
- Replaceable bladder design.
- Designed and constructed per ASME Code Section VIII, Division 1.
- Sight glass and seismic restraint options available
- Available with S/S system connection.

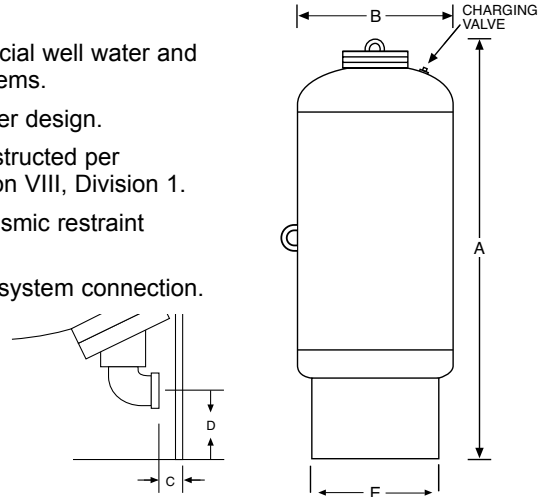

ASME Models

Model Number	Tank Volume		Max. Accept. Factor		A Tank Height		B Tank Diameter		C Sys. Conn. Inset		D Conn. Centerline		E Stand Diameter		System Conn. (NPTF)	Shipping Weight	
	Gal	Lit	Gal	Lit	In	mm	In	mm	In	mm	In	mm	In	mm		Lbs	Kg
WX-447C	53	200	53	200	45	1143	24	610	2	51	3¼	95	19	483	2	420	191
WX-448C	80	300	80	300	59	1498	24	610	2	51	3¼	95	19	483	2	492	223
WX-449C	106	400	106	400	73	1854	24	610	2	51	3¼	95	19	483	2	507	230
WX-450C	132	500	132	500	87	2210	24	610	2	51	3¼	95	19	483	2	570	259
WX-451C	158	600	158	600	73	1854	30	762	3½	89	5½	140	24	610	2	813	369
WX-452C	211	800	211	800	91	2311	30	762	3½	89	5½	140	24	610	2	1007	457
WX-453C	264	1000	264	1000	86	2184	36	914	3⅝	98	6¼	171	30	762	3	1095	497
WX-454C	317	1200	317	1200	98	2489	36	914	3⅝	98	6¼	171	30	762	3	1264	573
WX-455C	370	1400	370	1400	110	2794	36	914	3⅝	98	6¼	171	30	762	3	1350	612
WX-456C	422	1600	422	1600	82	2083	48	1219	7½	191	7⅝	181	42	1067	3	1700	771
WX-457C	528	2000	528	2000	97	2464	48	1219	7½	191	7⅝	181	42	1067	3	2231	1012
WX-458C	660	2500	660	2500	84	2134	60	1524	7⅝	194	7⅝	181	54	1372	4	2320	1052
WX-459C	792	3000	792	3000	99	2515	60	1524	7⅝	194	7⅝	181	54	1372	4	3470	1574
WX-460C	925	3500	925	3500	107	2718	60	1524	7⅝	194	7⅝	181	54	1372	4	3680	1669
WX-461C	1056	4000	1056	4000	121	3073	60	1524	7⅝	194	7⅝	181	54	1372	4	4220	1914
WX-462C	1320	5000	1320	5000	104	2642	72	1829	8⅝	213	4¾	121	60	1372	4	5600	2540
WX-463C	1980	7500	1980	7500	140	3556	72	1829	8	203	6	152	60	1372	4	6560	2976

All dimensions and weights are approximate.

Job Name _____	Notes _____
Engineer _____	_____
Contractor _____	_____
P.O. No. _____	_____
Sales Rep. _____	_____
Model No. _____	_____





WELL-X-TROL®

Full Acceptance Bladder Well Tanks: WX-440C – WX-460C Series ASME

300 PSIG Working Pressure

Construction

Shell	ASME Approved Steel
Full Acceptance Bladder	Heavy Duty Butyl
Bladder Thickness	.100 In. Minimum
Finish	Red Oxide Primer
Air Valve	Schrader Valve w/EPDM Seats
Factory Precharge	25 PSIG (1.7 bar)

Performance

Maximum Operating Temperature	240°F (115°C)
Maximum Working Pressure	300 PSIG (21 bar)
Warranty	1-Year

Application

- For use in commercial well water and booster pump systems.
- Replaceable bladder design.
- Designed and constructed per ASME Code Section VIII, Division 1.
- Sight glass and seismic restraint options available.
- Available with S/S system connection.

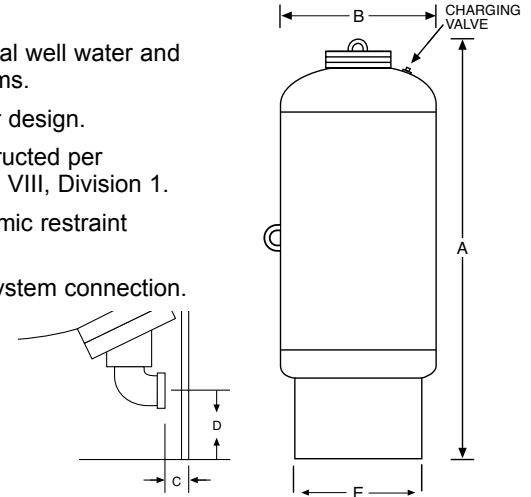

ASME Models

Model Number	Tank Volume		Max. Accept. Volume		A Tank Height		B Tank Diameter		C Sys. Conn. Inset		D Sys. Conn. Centerline		E Stand Diameter		System Conn. (NPTF)	Shipping Weight	
	Gal	Lit	Gal	Lit	In	mm	In	mm	In	mm	In	mm	In	mm		Lbs	Kg
WX-447C	53	200	53	200	45	1143	24	610	2	51	3¼	95	19	483	2	462	210
WX-448C	80	300	80	300	59	1498	24	610	2	51	3¼	95	19	483	2	540	245
WX-449C	106	400	106	400	73	1854	24	610	2	51	3¼	95	19	483	2	557	253
WX-450C	132	500	132	500	87	2210	24	610	2	51	3¼	95	19	483	2	627	284
WX-451C	158	600	158	600	73	1854	30	762	3½	89	5½	140	24	610	2	894	406
WX-452C	211	800	211	800	91	2311	30	762	3½	89	5½	140	24	610	2	1107	502
WX-453C	264	1000	264	1000	86	2184	36	914	3⅝	98	6¾	171	30	762	3	1204	546
WX-454C	317	1200	317	1200	98	2489	36	914	3⅝	98	6¾	171	30	762	3	1390	630
WX-455C	370	1400	370	1400	110	2794	36	914	3⅝	98	6¾	171	30	762	3	1485	674
WX-456C	422	1600	422	1600	82	2083	48	1219	7½	191	7⅝	181	42	1067	3	1826	828
WX-457C	528	2000	528	2000	97	2464	48	1219	7½	191	7⅝	181	42	1067	3	2450	1111
WX-458C	660	2500	660	2500	84	2134	60	1524	7⅝	194	7⅝	181	54	1372	4	2750	1247
WX-459C	792	3000	792	3000	99	2515	60	1524	7⅝	194	7⅝	181	54	1372	4	3690	1674
WX-460C	925	3500	925	3500	107	2718	60	1524	7⅝	194	7⅝	181	54	1372	4	3910	1773
WX-461C	1056	4000	1056	4000	121	3073	60	1524	7⅝	194	7⅝	181	54	1372	4	4485	2034
WX-462C	1320	5000	1320	5000	104	2642	72	1829	8⅝	213	4¾	121	60	1372	4	5950	2699
WX-463C	1980	7500	1980	7500	140	3556	72	1829	8	203	6	152	60	1372	4	6970	3162

All dimensions and weights are approximate.

Job Name _____	Notes _____
Engineer _____	_____
Contractor _____	_____
P.O. No. _____	_____
Sales Rep. _____	_____
Model No. _____	_____





WELL-X-TROL®

Partial Acceptance Bladder Well Tanks: WX Series ASME

125 PSIG Working Pressure

Construction

Shell	ASME Approved Steel
Bladder Material	Heavy Duty Butyl
Bladder Thickness (models 35-100)	.087 In. Minimum
Bladder Thickness (models 130-600)	.100 In. Minimum
System Connection	Malleable Iron (NPTF)
Finish	Red Oxide Primer
Air Valve	Schrader Valve w/ EPDM Seats
Factory Precharge	25 PSIG (1.7 bar)

Performance

Maximum Operating Temperature	240°F (115°C)
Maximum Working Pressure	125 PSIG (8.6 bar)
Warranty	1-Year

Application

- For use in commercial well water and booster pump systems.
- Replaceable bladder design.
- Sight glass and seismic restraint options available.
- Designed and constructed per ASME Code Section VIII, Division 1..

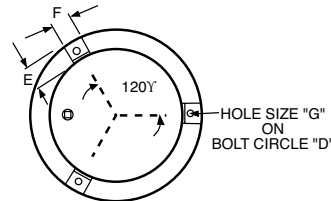

BOTTOM VIEW

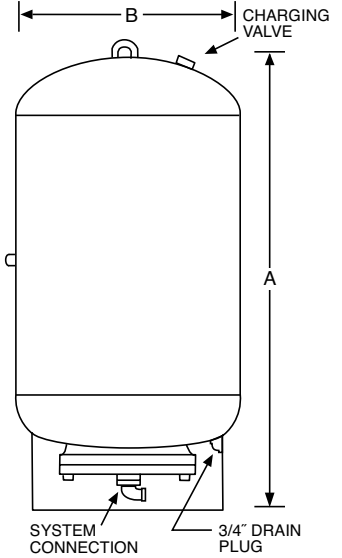

ASME Models

Model Number	Tank Volume		Max. Accept. Volume		A Tank Height		B Tank Diameter		System Conn. (NPTF)	Shipping Weight	
	Gal	Lit	Gal	Lit	In	mm	In	mm		In	Lbs
WX-35CL	10	35	10	35	37	941	10	254	1¼	69	32
WX-50CL	13	50	11	40	37	941	12	305	1¼	76	35
WX-85CL	22	85	11	40	35	889	16	406	1¼	92	42
WX-100CL	26	100	11	40	39	991	16	406	1¼	98	45
WX-130CL	34	130	27	100	35	889	20	508	1½	136	62
WX-165CL	44	165	27	100	40	1016	20	508	1½	146	67
WX-200CL	53	200	27	100	41	1041	24	610	1½	198	91
WX-300CL	80	300	27	100	56	1423	24	610	1½	236	108
WX-400CL	106	400	53	200	69	1743	24	610	2	282	129
WX-500CL	132	500	53	200	83	2108	24	610	2	316	144
WX-600CL	158	600	53	200	67	1702	30	762	2	450	206

All dimensions and weights are approximate.

Optional Seismic Restraints

Tank Diameter	Bolt Circle	Dim.	Dim.	Hole Size
B	D	E	F	G
10	12½	2	2	⅜
12	14¾	2	2	⅜
16	14¾	2	2	⅜
20	14¾	2	2	⅜
24	18	2	2	⅜
30	21½	3	3	¾

Job Name _____	Notes _____
Engineer _____	_____
Contractor _____	_____
P.O. No. _____	_____
Sales Rep. _____	_____
Model No. _____	_____

