

SUBMITTAL DATA SHEET

XR-21J-16-36-ZDC X-RISER

1" MNPT x 1" IPS SDR 11

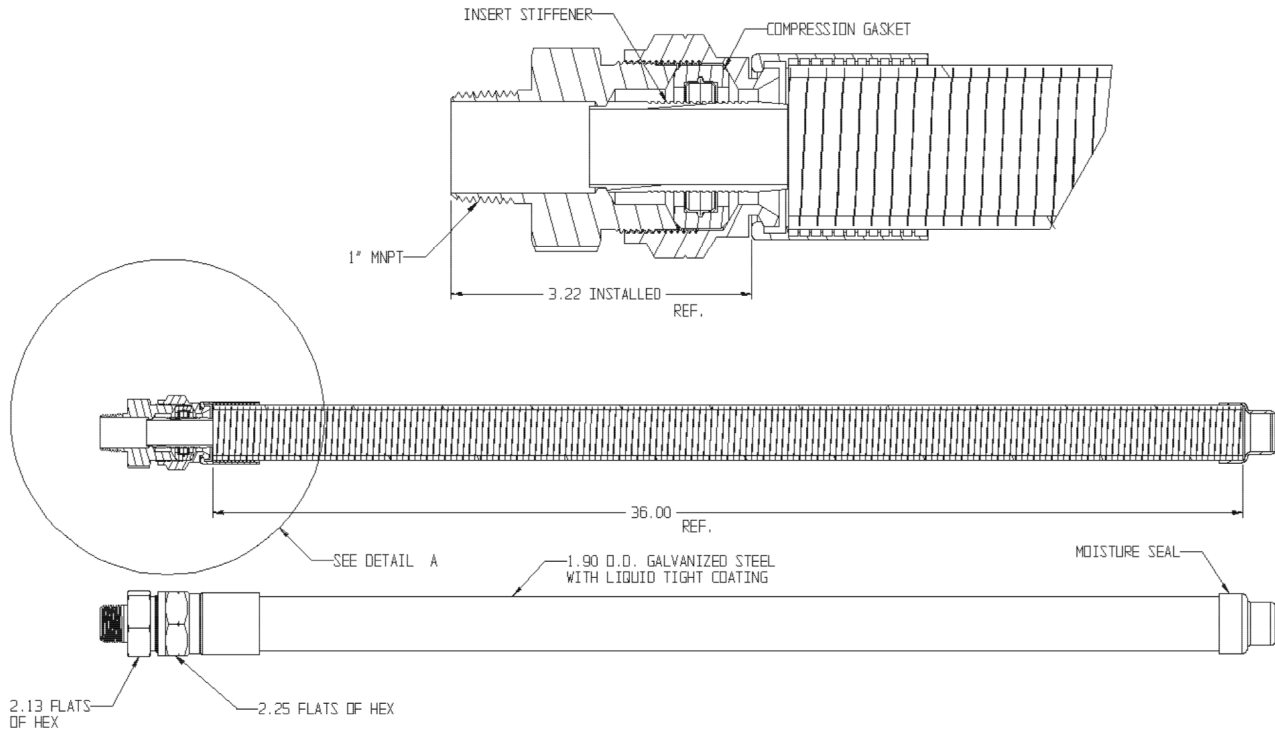

SUBMITTAL INFORMATION

- Bodies, Nuts and Stiffeners made of C12L14 Steel
- 70 Durometer Buna-N Seals
- Ferrules made of C1050 Steel
- Gray E Coating per ASTM D870, ASTM D1735, ASTM D2794, ASTM D3363
- ZDC = Yellow Trivalent Zinc Plating per ASTM B633 VI
- Meets all applicable requirements defined under 49CFR Part 192, D.O.T. 192.281, 192.283(b), 192.375, ASTM D2513 Category 1, ASTM F1973, ASTM F1948-12 Category 1, NFPA 58, NFPA 54 (ANSI Z223.1) and IFGC Section 403. IAPMO/UPC/IPC Listed.



Chicago Fittings
3170 E Colley Road
Beloit, WI 53511

Toll Free: 1-877-638-9009

Fax: 1-608-299-8901

Hours: 7:30 a.m. – 4:30 p.m., CST

info@chicagofittings.com

www.chicagofittings.com

Chicago Fittings considers the information on this assembly drawing correct when published. Item and option availability, including specifications, are subject to change without notice.

Submitted by:

07-20