

Take Control.
ION
Technologies

A division of Metropolitan Industries, Inc.



BA75i

Sump Pump

- Basement Sump
- Dewatering

3 YEAR
RESIDENTIAL
WARRANTY



37 Forestwood Dr., Romeoville, IL 60446
www.ionproducts.net [815] 886-9200

Patent No. 8,591,198

BA75i

Sump Pump

System Specifications

Typical Applications	<ul style="list-style-type: none">• Basement sump• Dewatering
Maximum Capacity	Up to 85 GPM
Maximum Head	Up to 37'
Electrical Data	115 V, 1 Ø, 7.5 FLA, 60 Hz
Motor Data	¾ HP, 3450 RPM
Minimum Sump Diameter	18"
Automatic Operation	i: Ion Digital Level Control (standard) SPI: Vertical float
Manual Operation	M: Manual
Materials of Construction	Cast iron & stainless steel
Impeller	Cast iron vortex
Power Cord	20' Standard
Discharge Size	2" NPT
Solids Handling	½"

Pump Dimensions

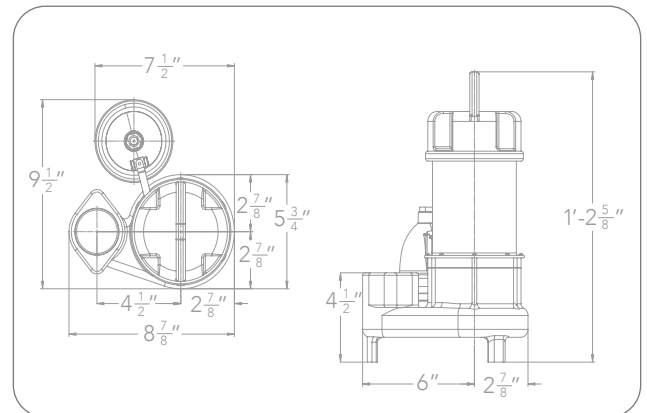

Pump Performance

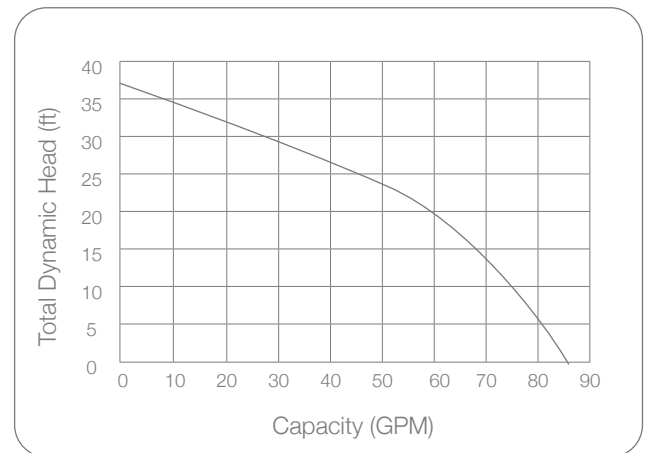

Features

- Energy efficient motor
- Carbon ceramic mechanical seal
- Thermal overload protection
- Ion® digital level control piggyback switch has no moving parts (standard)
- Stainless steel screen prevents debris from entering the pump
- 3 year residential warranty