

Take Control.
ion
Technologies

A division of Metropolitan Industries, Inc.



Ion+TM

3 YEAR
WARRANTY



Digital Level Control with High Water Alarm

- World's first digital piggyback style sump & sewage pump level control sensor with integrated alarms
- Provides alarm notification via an audible alarm, LED indicators, and dry alarm contact
- Device can be connected to external alarm notification systems such as our Ion Gateway[®] or MetroMail[™] systems, for real-time notification capability
- Ion[®] digital level control technology provides superior performance and reliability when compared to industry standard mechanical pump switches



37 Forestwood Dr., Romeoville, IL 60446
www.ionproducts.net [815] 886-9200

Patents Pending,
Patent No. 8,591,198,
9,033,686 and 9,680,401

Typical Installation Diagram

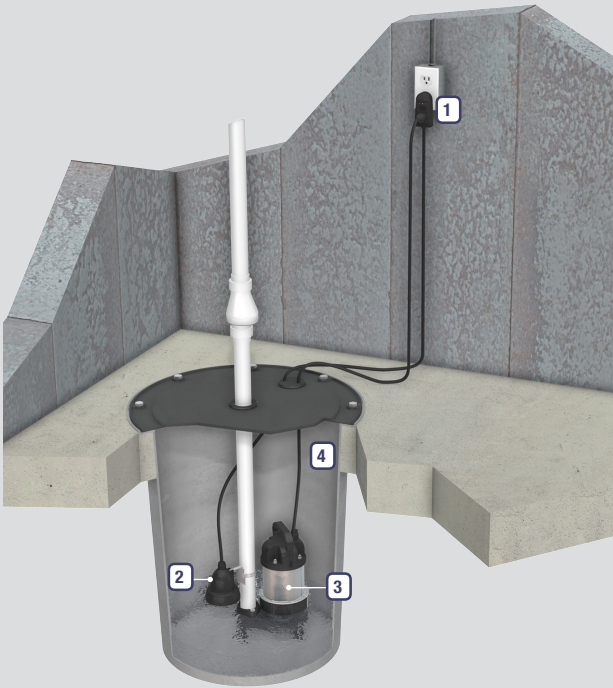

1. Ion+ piggyback plug with audible alarm and visual status LEDs
2. Ion+ digital level control sensor
3. Standard Ion Technologies pump (not included)
4. Basin (not included)

Switch Dimensions

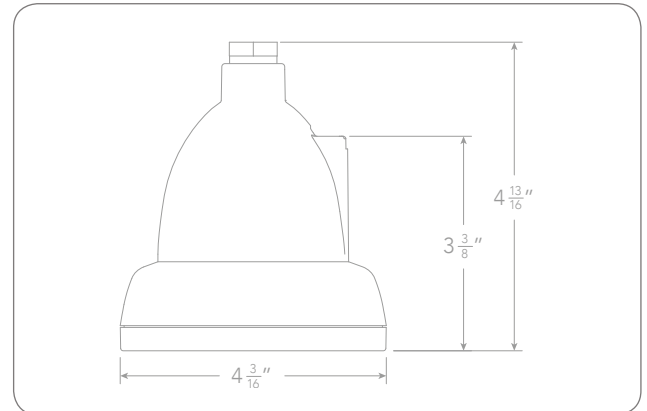

Piggyback Plug Illustration

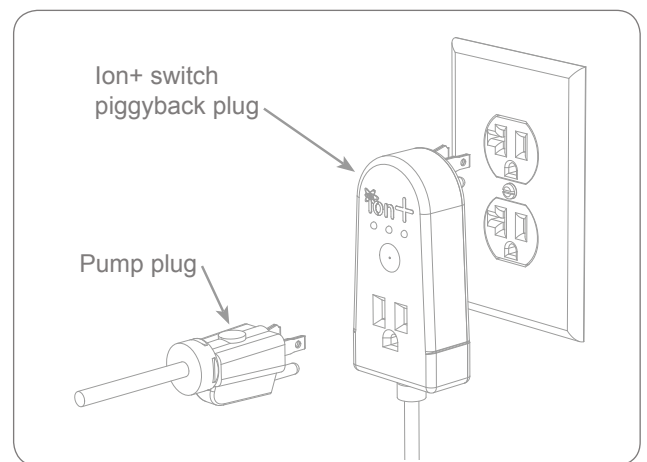

System Specifications

- Built in alarm and monitoring system
- Power, system and high water LEDs indicate system status
- Audible alarm
- Dry contact
- Remote alarm port - type RJ11
- First of a kind solid-state sensing technology with no moving parts
- Starts and stops pump via the piggyback pump power receptacle
- Multipoint sealing mechanism that supersedes single surface seals
- Inverter rated for use with most battery backup systems
- No contact points
- 3 year warranty
- Part Number: iNP20306