

Take Control.
ION
Technologies

A division of Metropolitan Industries, Inc.



SE40-60i

3 YEAR
RESIDENTIAL
WARRANTY



Sewage Pump

- Septic tank effluent
- High capacity sump
- Residential sewage
- Light commercial sewage



37 Forestwood Dr., Romeoville, IL 60446
www.ionproducts.net [815] 886-9200

Patent No. 8,591,198

SE40-60i

Sewage Pump

System Specifications

Typical Applications	• Septic tank effluent
	• High capacity sump
	• Commercial sewage
	• Residential sewage
<hr/>	
Maximum Capacity	SE40: Up to 117 GPM SE60: Up to 174 GPM
<hr/>	
Maximum Head	Up to 26'
<hr/>	
Electrical Data	SE40M-1: 115 V, 1 Ø, 11 FLA, 60 Hz SE60M-1: 115 V, 1 Ø, 12 FLA, 60 Hz SE60M-01: 208 V, 1 Ø, 7.5 FLA, 60Hz SE60M-21: 230 V, 1 Ø, 6.0 FLA, 60Hz SE60M-23: 230 V 3 Ø, 4.5 FLA, 60Hz SE60M-43: 460 V, 3 Ø, 2.3 FLA 60Hz, SE60M-03: 208 V, 3 Ø, 4.7 FLA, 60Hz
<hr/>	
Motor Data	SE40: 4/10 HP, 1750 RPM SE60: 6/10 HP, 1750 RPM
<hr/>	
Recommended Minimum Basin Size	18" x 30"
<hr/>	
Automatic Operation	i: Ion Digital Level Control (standard) W: Wide angle switch
Manual Operation	M: Manual
<hr/>	
Materials of Construction	Cast iron
<hr/>	
Impeller	Cast iron, 2-vane
<hr/>	
Power Cord	20' Standard
<hr/>	
Discharge Size	2" NPT (3" NPT optional)
<hr/>	
Solids Handling	2"

Pump Dimensions

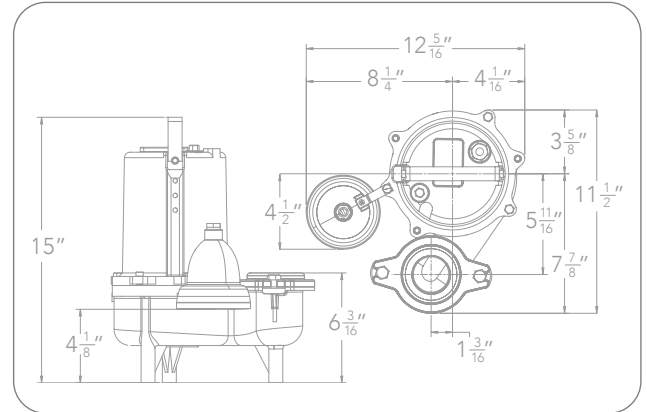

Pump Performance

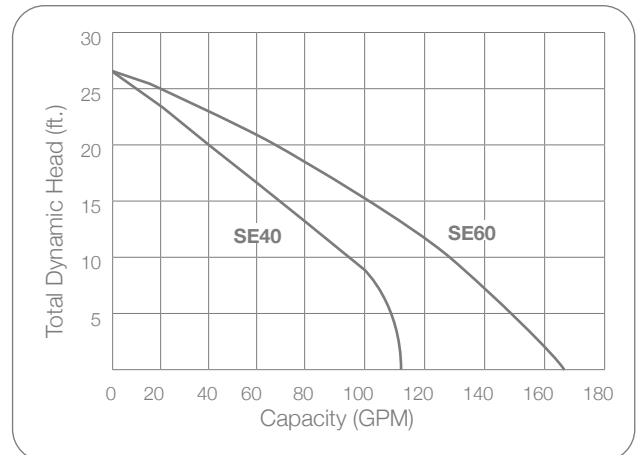

Features

- Carbon ceramic mechanical seal
- Oil-filled high efficiency PSC motor
- Uses single-row ball-bearing construction
- Ion® digital level control piggyback switch has no moving parts (standard)
- 3 year residential warranty